

### Load Data



span (ft)	Uniform Loads			Center Pt. Load		Third Pt. Load		Quarter Pt. Load	
	load (plf)	load (lbs)	defl (in)	load (lbs)	defl (in)	load (lbs)	defl (in)	load (lbs)	defl (in)
10	827	8272	0.03	2418	0.01	1209	0.01	1531	0.02
15	548	8223	0.10	2370	0.05	1185	0.04	1515	0.07
20	409	8174	0.23	2321	0.11	1160	0.09	1499	0.16
25	325	8126	0.46	2272	0.21	1136	0.18	1482	0.32
30	269	8077	0.79	2223	0.36	1111	0.31	1466	0.55
35	197	6885	1.08	2174	0.57	1087	0.49	1450	0.87
40	148	5933	1.41	2125	0.84	1063	0.73	1434	1.30
45	115	5181	1.78	2076	1.19	1038	1.04	1295	1.70
50	91	4570	2.20	2027	1.62	1014	1.41	1143	2.10
55	74	4062	2.66	1979	2.14	989	1.87	1015	2.54
60	60	3629	3.17	1815	2.62	965	2.42	907	3.03

### Component Weights

Part No	Description	WT (lbs)
HFFT3M	3m section	123
HFFT2M	2m section	87
HFFT1M	1m section	62
HFFTC4	4 way corner section	90
HFFTS4N	4 way sleeve section	98

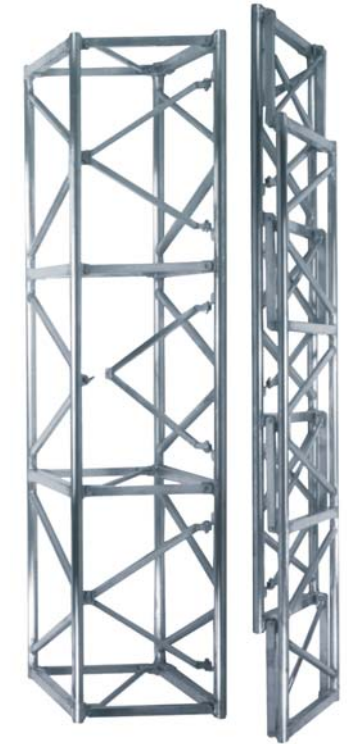

### Dimensions

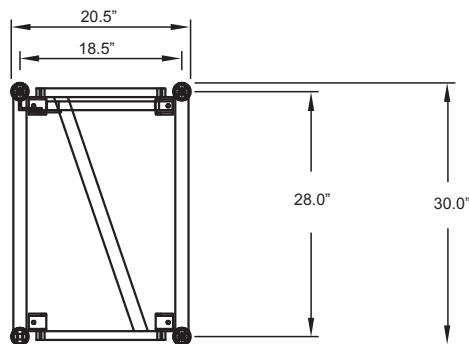

### 3d view

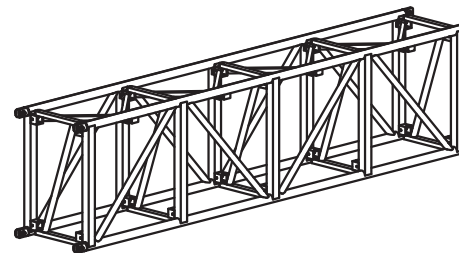

### Truss Features

#### Description

- External Dimensions
- Connection Centers
- Material Type
- Connector Type
- Maximum Certified Span

#### Specification

- 20-1/2" w. x 30"h.
- 18-1/2" w. x 28"h.
- 6061-T6 Aluminum
- Steel fork ends
- 60ft